

創作・折図 あおやぎしょうこ

©Shoko Aoyagi January 2005

(体)

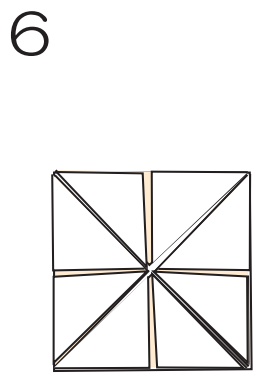
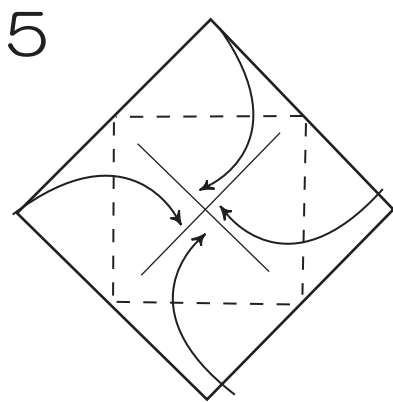
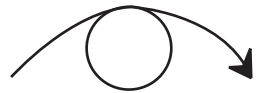
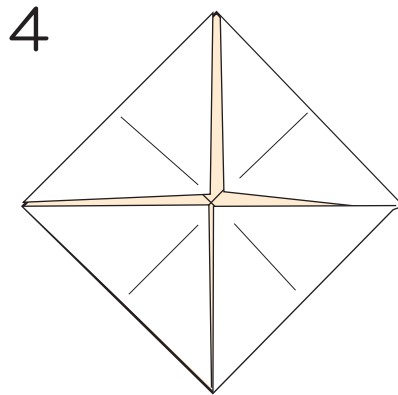
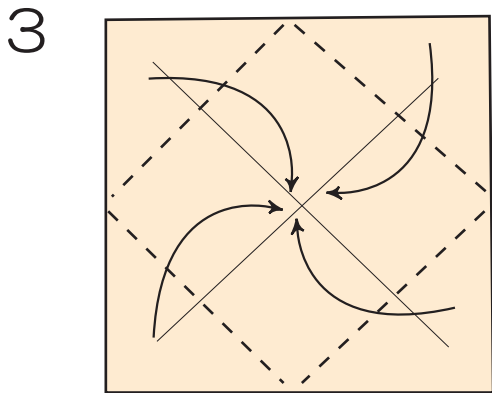
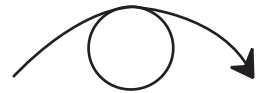
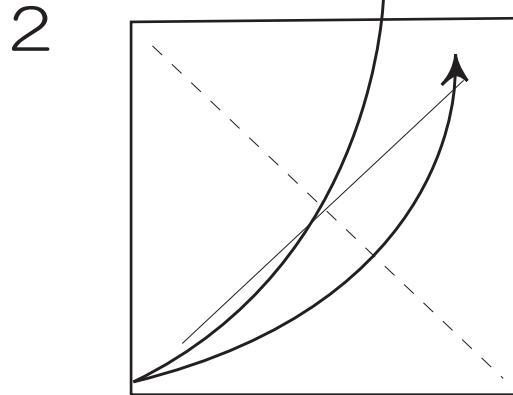
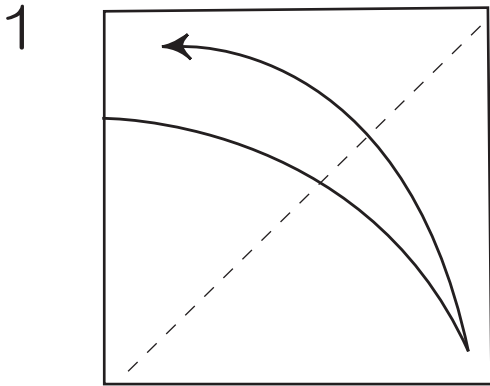
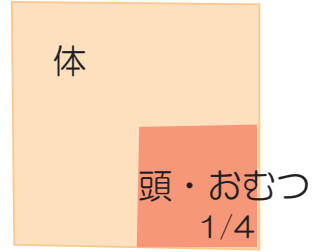

広げる。

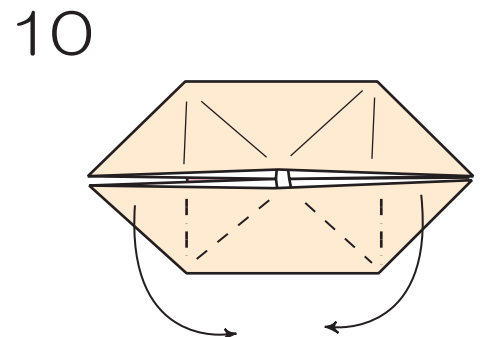
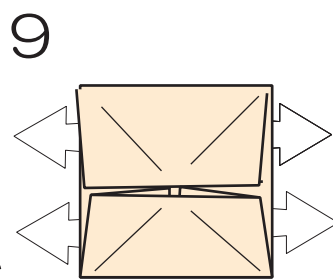
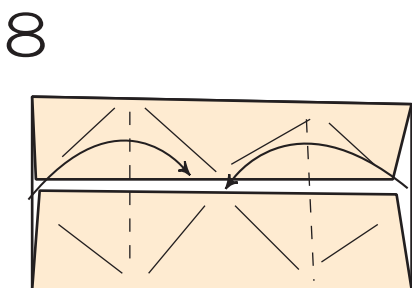
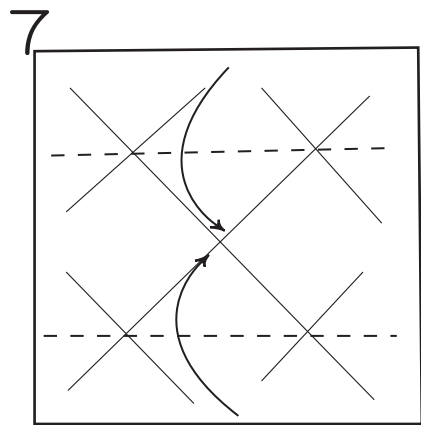

創作・折図 あおやぎしょうこ

©Shoko Aoyagi  
January 2005

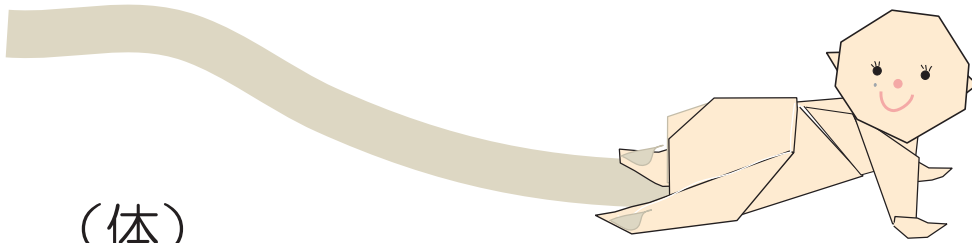

(体)

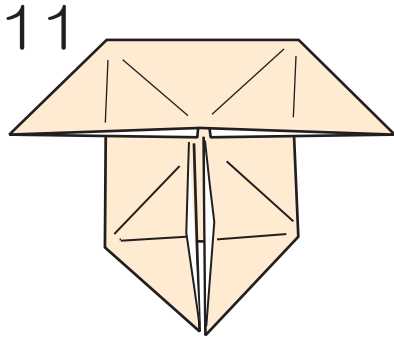

12

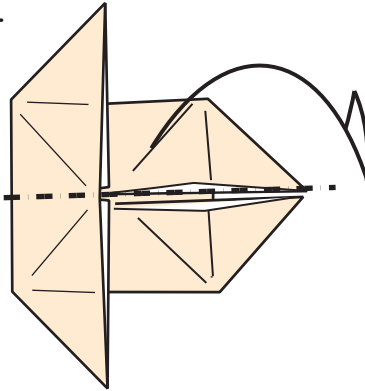

13

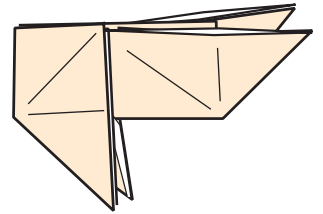

14

hinge

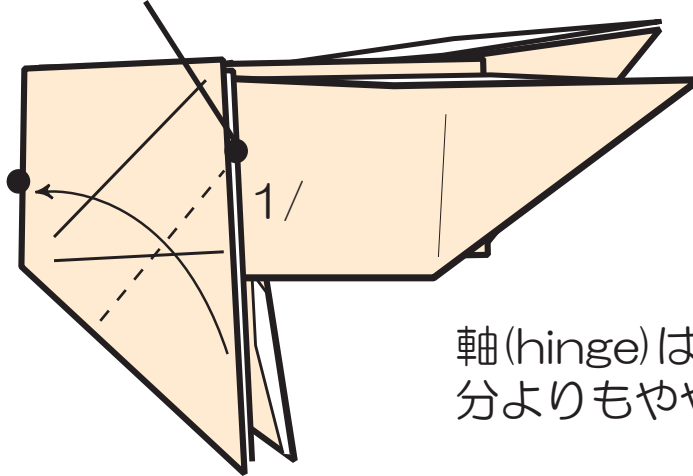
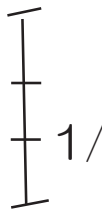

軸(hinge)は、正方形の半分よりもやや上になる。

15

16

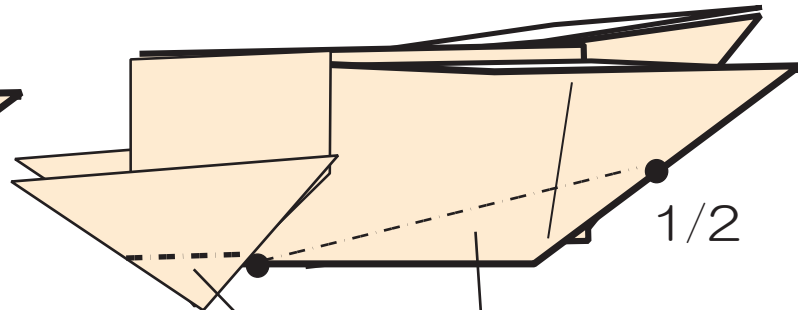
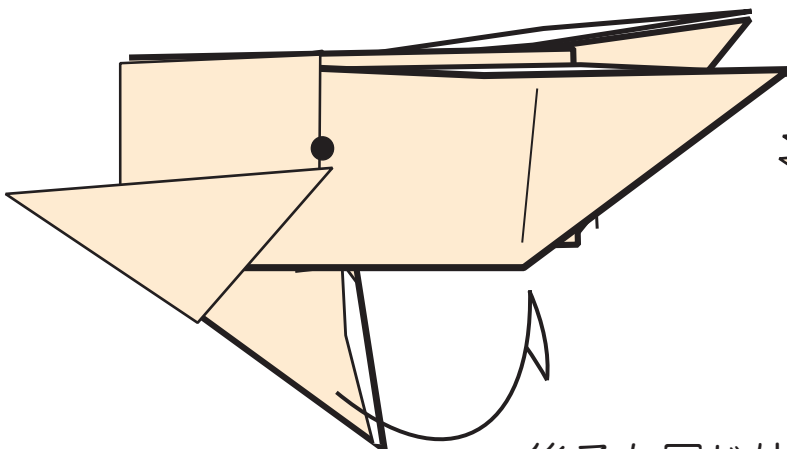

内側に折りこむ。  
後ろも同様に折る。

後ろも同じ位置になる  
ように後ろに折る。

創作・折図 あおやぎしょうこ

©Shoko Aoyagi January 2005



(体)

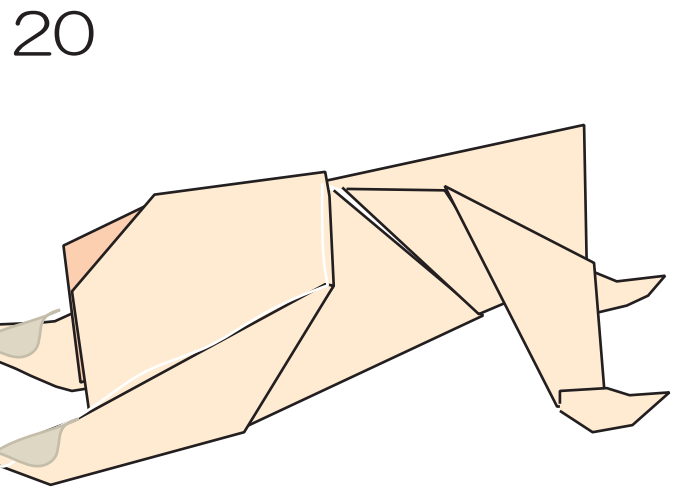
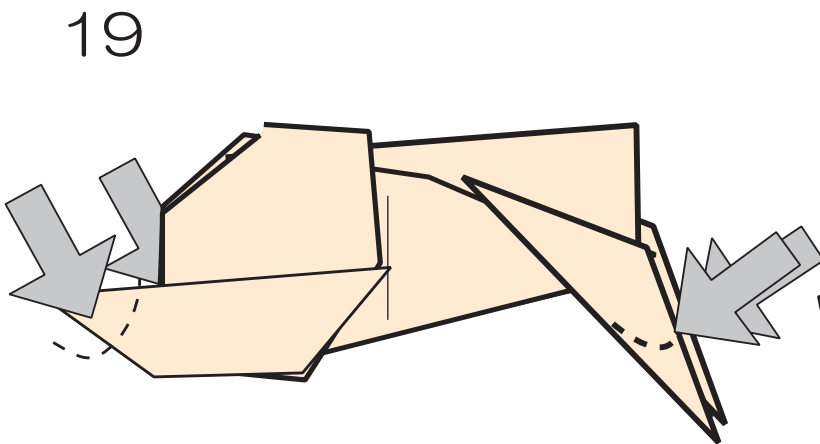
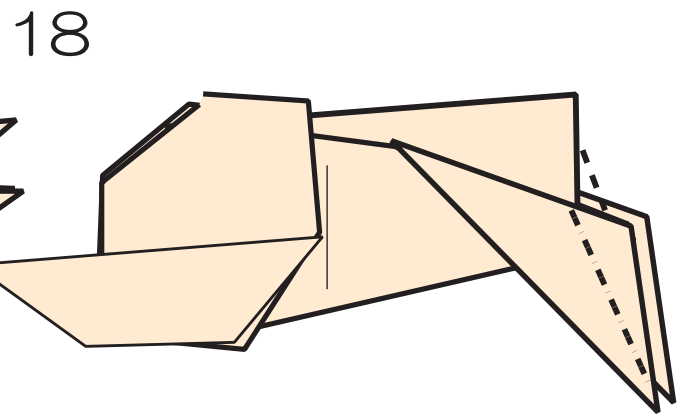
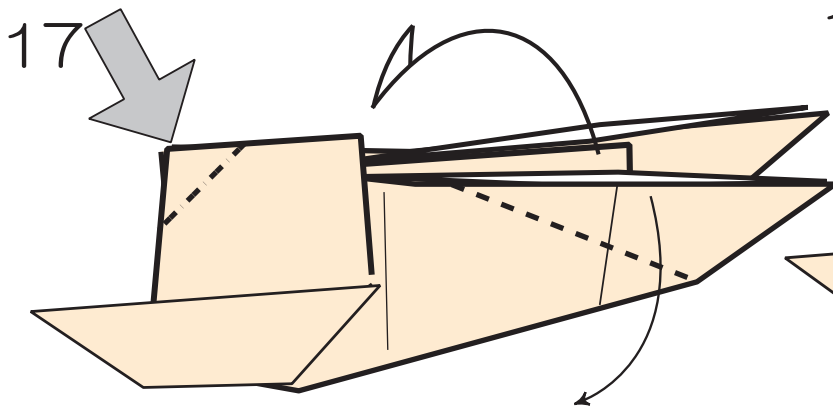

創作・折図 あおやぎしょうこ

©Shoko Aoyagi January 2005



(頭)

1

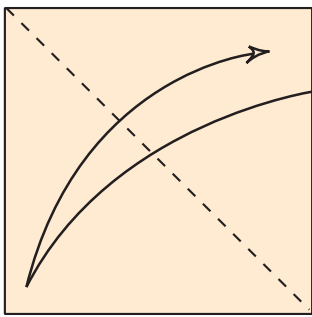

2

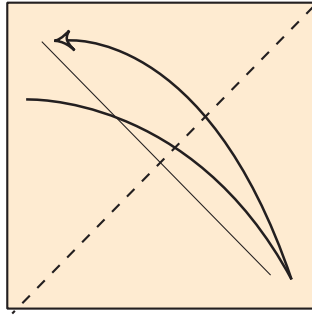

3

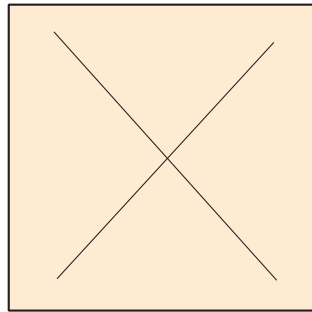

4

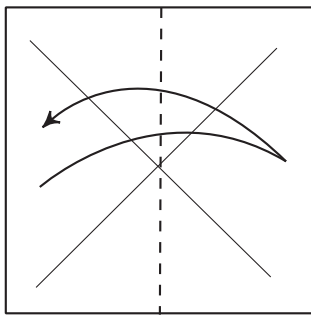
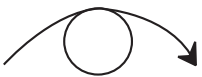

5

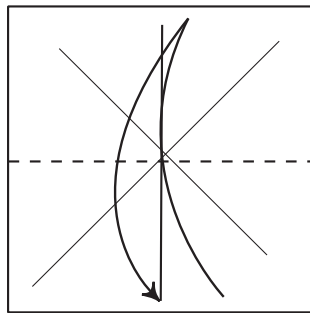

6

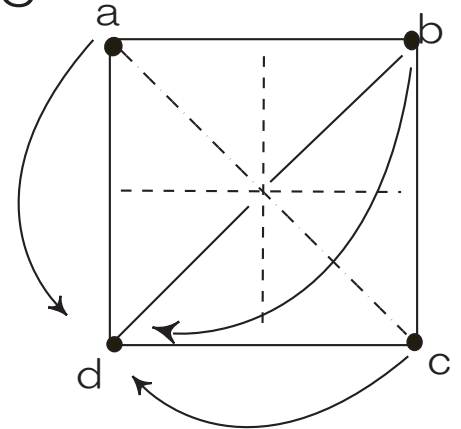

7

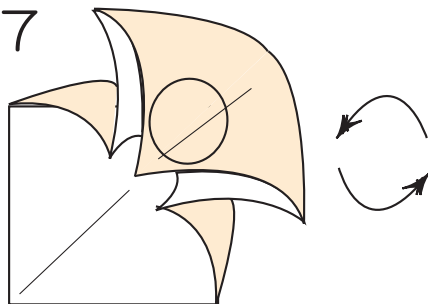

8

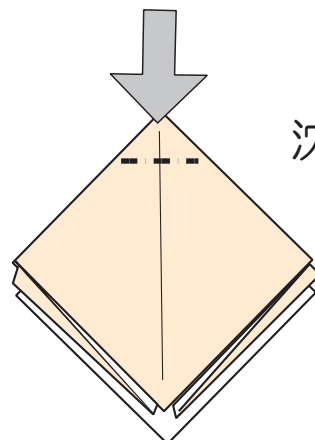

沈め折

創作・折図 あおやぎしょうこ

©Shoko Aoyagi January 2005

(頭)

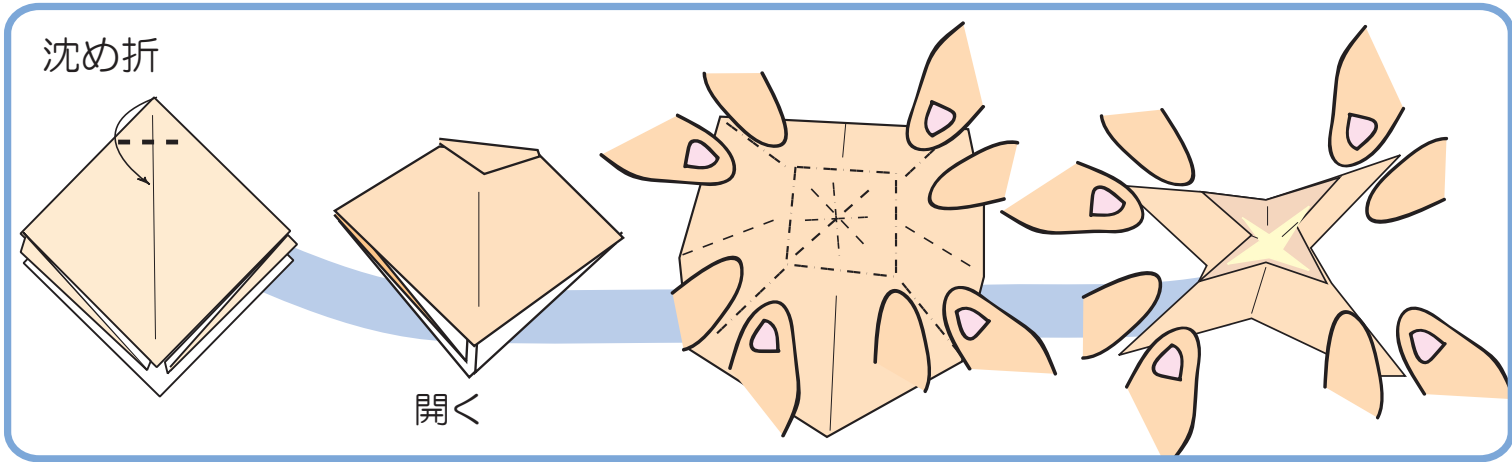
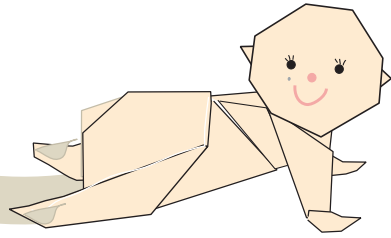

沈め折

開く

9

沈め折

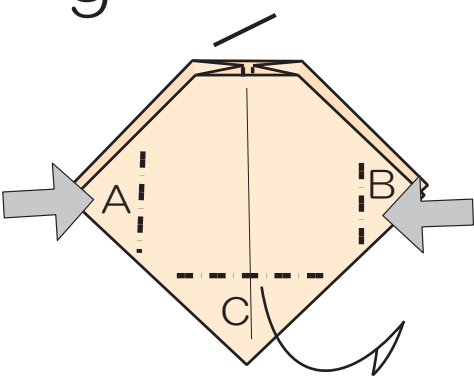

10

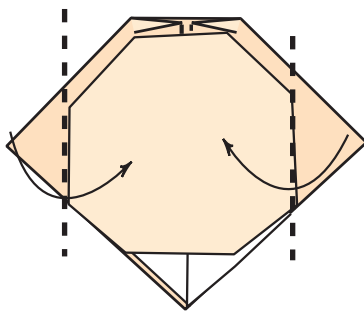

11

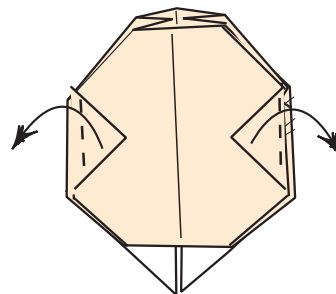

12

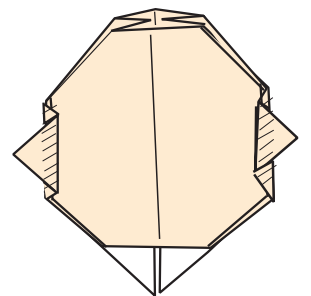

斜線の部分は下に入れ込む。

13

頭の出来上がり。  
顔を描きましょう。  
aは、cの手前に。  
bは、cの後ろに差し込みます

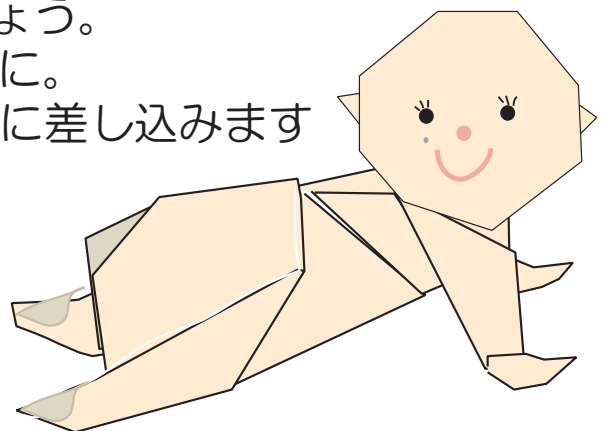
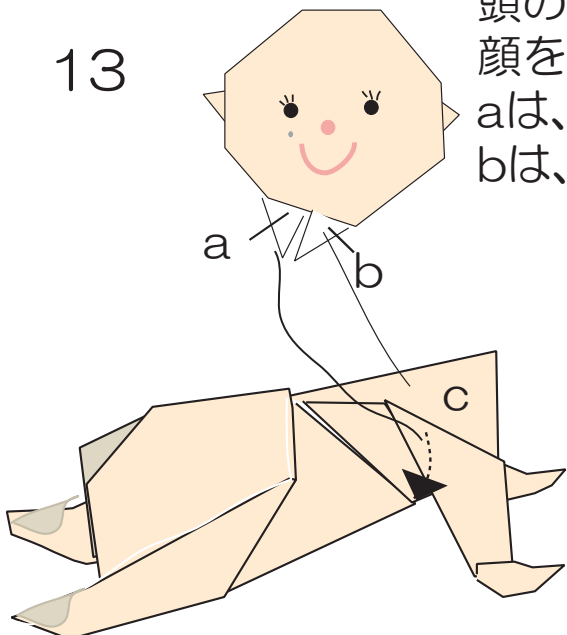

ハイハイしている赤ちゃんの出来上がり。

創作・折図 あおやぎしょうこ

©Shoko Aoyagi January 2005

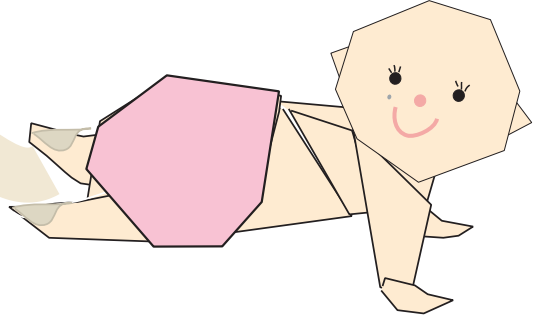

(オムツ (カード) の作り方)

1

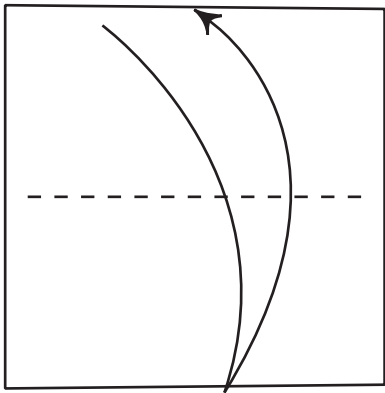

2

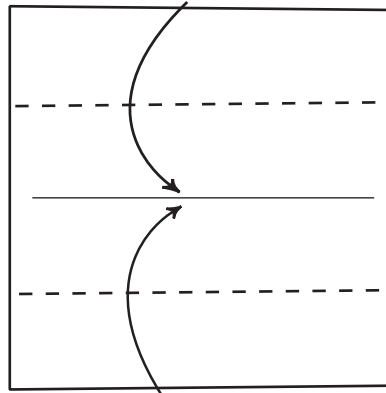

3

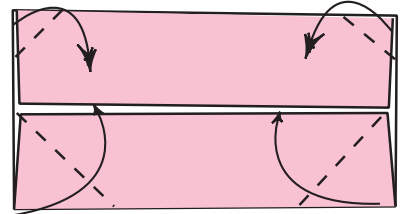

4

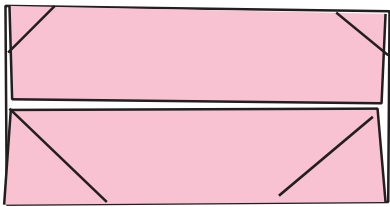

5

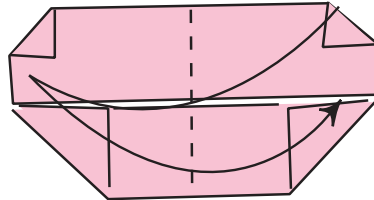

6

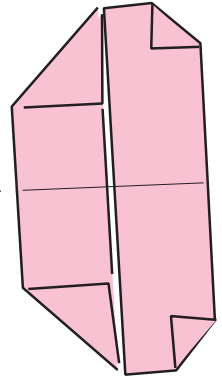

7

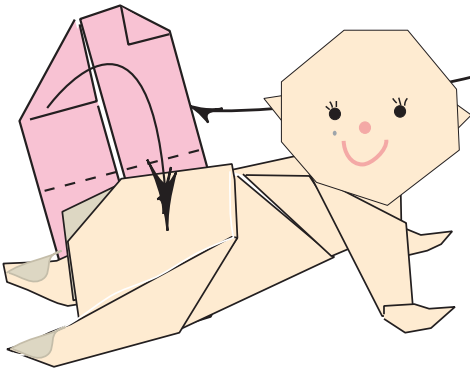

押し込む。

8

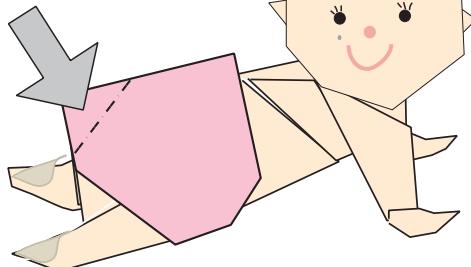

9

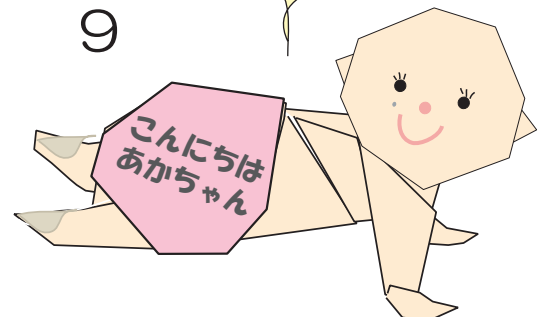

カードのメッセージは折図の1 又は、3の上に書けるよ。